

TS110

Self Powered Governor



www.tri-sen.com



TS110

Self Powered Governor

Description

The TS110 is a self powered electronic governor designed for single-valve steam turbines and reciprocating engines. By using high output magnetic speed pickups, the governor can be operated with no external power.

Applications

The TS110 is applied to both generator and mechanical drive applications where there is no external power available, often in remote locations or mechanical governor retrofits. The TS110 is used on a wide variety of applications including process fans, pumps, and compressors.

Features

- *Self Powered* - operates without external power
- *Isochronous (PID) and droop (PIP) speed/load control* - provided for both generator and mechanical drives
- *Dual pickup selector circuit* – with lost signal indication
- *Remote speed setpoint* – allows control from external signal
- *Modular Design* - all components, including the controller board, can be replaced in minutes, minimizing downtime
- *Integral I/P* - provides 3-15 PSIG air signal
- *Remote Start Capability* - can be started by an external signal
- *Underspeed Switch* - on an underspeed condition, an operating 110 can start a backup turbine controlled by a second TS110
- *Electronic Overspeed Trip Relay* - allows precise selection of overspeed trip for additional protection
- *Digital Tachometer Readout* - eliminates the need for vibrating reed tachometer
- *Accommodates 1 and 2 magnetic pickups* - Pickup select circuit keeps unit running on a single pickup to increase availability
- *Nonlinear Gain* - dampens output pulsations in reciprocating engine applications
- *Rugged Design* – NEMA 4X SS weather-proof enclosure standard



TS110

Self Powered Governor

Typical Configuration

The TS110 utilizes one or two high-power magnetic pickup(s) for power and speed signal. The tooth of a ferrous gear passing under the magnetic pickup creates an AC pulse. This pulse is converted to a DC voltage to power the controller. The pulse rate (or frequency) is also converted into a DC voltage that is compared to a setpoint voltage. The difference is sent through a Proportional/Integral/Derivative loop and converted to a current signal to drive an I/P (current to pressure) transducer. The I/P transducer converts the signal to a 3-15 PSIG (pounds per square inch, gauge) low consumption air signal. The air signal is sent to a pneumatic diaphragm actuator and air booster or a piston type actuator with positioner, depending on size and specifications of the turbine. The actuator is coupled directly, or through linkage, to the valve stem.

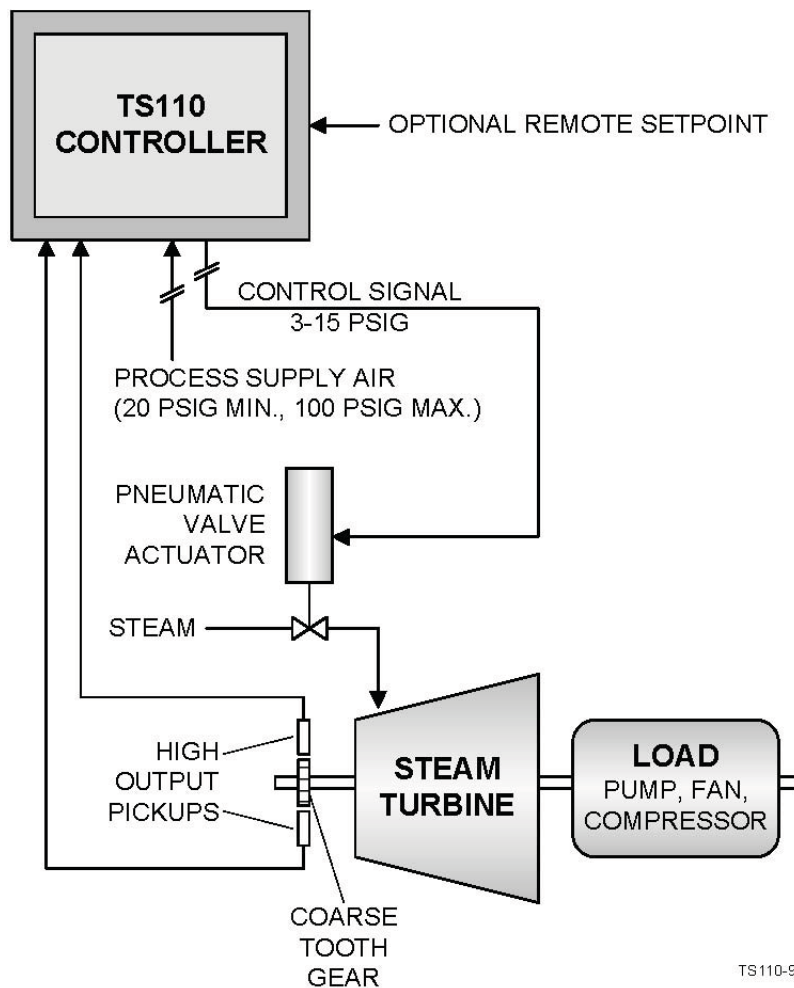

TS110-9

TS110

Self Powered Governor

Specifications

Inputs

- Speed Sensors: 2 ea. (3 Vrms / 15 mA, 200 - 10,000 Hz)
- Remote Start: 4-20 mA or 5 V / 4 mA
- Setpoints: Local potentiometer, Remote potentiometer, Remote 4-20 mA, Remote 3-15 psig
- Switches: Overspeed test, Run switch

Outputs

- Actuator: 3-15 psig, 2.0 CFM at nominal 20 psig supply
- Supply Pressure: Min: 18 psig / Max: 50 psig
- Overspeed Trip: Isolated SCR, 400 V max, 0.3 A, max, 0.15 A min.
- Low Speed Switch: 5 V / 4 mA
- Analog Tachometer: 0 - 50 mA
- Digital Tachometer: 5 V pulse
- Speed Regulation: Exceeds NEMA D
- Area Classification: Non-incendive Class 1, Gr. A,B,C,D, Div. 2

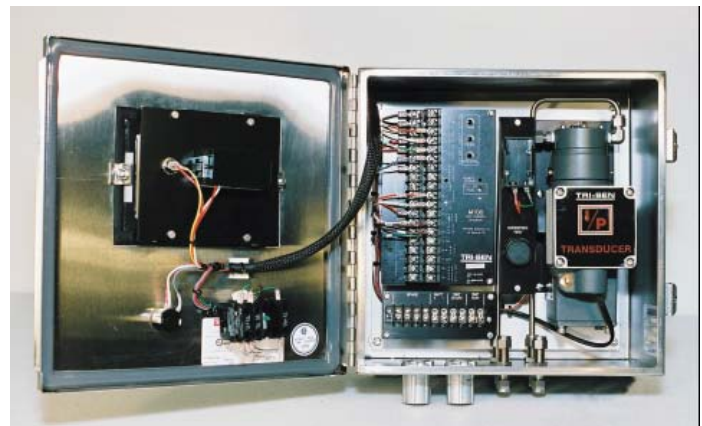

Power Supply

- N/A - Self Powered

Display

- Integrated operator interface including digital tachometer readout, run/stop/start and speed setpoint switches

Environmental Specifications

- Temperature: -20°F to 160°F
- Humidity: 0 - 95% non-condensing

TS110

Self Powered Governor

Dimensions

- Surface mount: 12.22”h x 12.22”w x 6.1”d

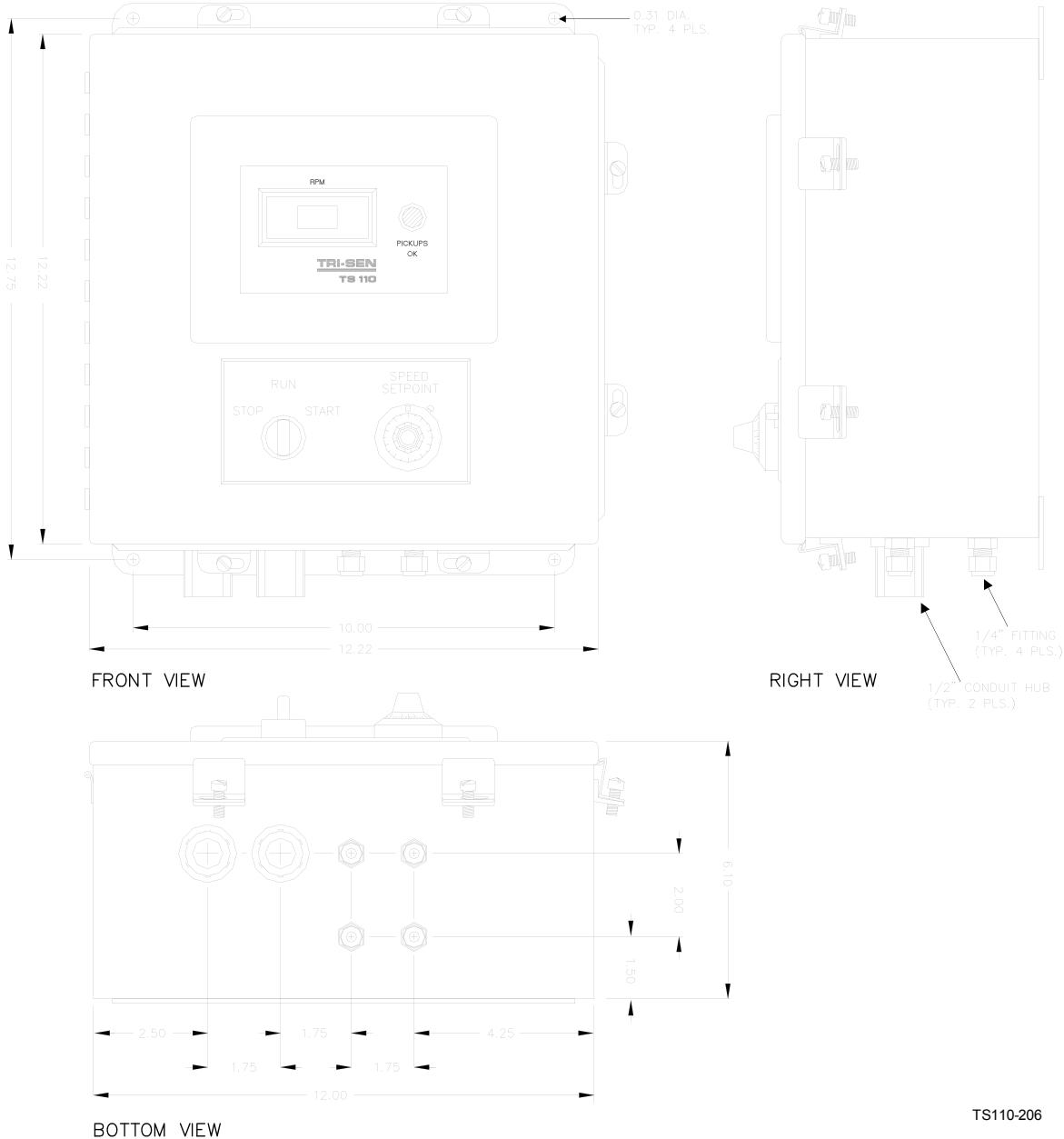

TS110-206



TS110

Self Powered Governor

Ordering Information

Model Number

Description

Controls

91-0979 TS110 Self-Powered Configurable controller

Spare Parts

91-1333 M115 Simulator
(The M115 simulator/calibrator is a portable, precision, test instrument designed for use with the TS110. It provides complete test, calibration and simulation support)

90-0364 M100 PBA Assembly

7131-0004 High Output Pickup

0091-1452 3" 20 Tooth Gear

0091-1203 3" 16 Tooth Gear

7015-0000 N.O. Solid State Relay

6011-0009 100K Pot (Local Speed Set)

9945-0010 I/P Converter; 1-5 mA to 3-15PSIG

20-6855 Switch - Run/Stop/Start

Manual

Manual TS110 TS110 Manual set

Optional Accessories

85-3204 Manual Loading Station

Configuration Specification Sheet (page 1)

Date: _____
Customer: _____
Customer Order Number: _____
Tri-Sen Order Number: _____
Customer Contact (Name & Phone): _____
End User (Name & Location): _____

Please complete the following for your application. This information will be used to determine the configuration of your TS110.

Gear Specifications

Diameter of Gear = _____ inches
Number of Gear Teeth = _____ teeth

NOTE: Tri-Sen recommends you use one of the following two standard gears:

- 3 inch, 20 teeth
- 5 inch, 30 teeth

Controller Parameters

Minimum Governor Speed = _____ RPM
Maximum Governor Speed = _____ RPM
Electronic Overspeed Trip = _____ RPM
Underspeed (if used) = _____ RPM
Mechanical Overspeed Trip = _____ RPM

Configuration Specification Sheet (page 2)

Setpoint Selection

Choose *one* of the following:

- 1. Local potentiometer only.
- 2. Local potentiometer and remote potentiometer.
- 3. Local potentiometer and 4 to 20 mA current signal.
- 4. Local potentiometer and 3 to 15 psig pneumatic signal.
- 5. 4 to 20 mA current signal only.
- 6. 3 to 15 psig pneumatic signal only.
- 7. Remote potentiometer only.

Remote Setpoint Action

Reverse Action means that an increase in signal will cause a decrease in the desired speed.

Direct Action means that an increase in the signal will cause an increase in the desired speed. (This is most commonly used.)

4-20mA current setpoint

- Direct Reverse Not Used

3-15 psig setpoint

- Direct Reverse Not Used

Local/Remote Setpoint Select

High Select causes that local setpoint to override the remote setpoint when the local setpoint is set to a higher value.

Configuration Specification Sheet (page 3)

Low Select causes the local setpoint to override the remote setpoint when the local setpoint is set to a lower value.

- High Select Low Select Not Used

Remote Start Option

Remote start via 4-20mA current setpoint

- Not Required Required

NOTE: If Remote Start via 4-20mA is selected, a “Reset” switch must be placed in the Remote Speed Setpoint 4-20mA loop to momentarily interrupt the current loop to reset the Remote Start feature for another startup.

Power Option

TS110 powered via

- Magnetic Pickups External

Controller Action

Reverse Action means that an increase in speed will cause a decrease in the output to the actuator. (This is most commonly used.)

Direct Action means that an increase in speed will cause an increase in the output to the actuator.

- Reverse Direct

Operating parameters

Air Supply Pressure = _____ psig (18-100 psig limit)